

Treating Hyperinsulinemia with *Momordica charantia*

Frank Comhaire*

Department of Endocrinology, Ghent University Hospital, Belgium

*Corresponding author: Prof. Frank Comhaire, Brakelmeersstraat, 18 B9830 Sint Martens-Latem, Belgium, Tel: +32 475 618 555; E-mail: Frank@comhaire.com

Rec Date: May 15, 2015; Acc Date: June 30, 2015; Pub Date: July 5, 2015

Copyright: © 2015 Comhaire. This is an open-access article distributed under the terms of the Creative Commons Attribution License, which permits unrestricted use, distribution, and reproduction in any medium, provided the original author and source are credited.

Abstract

Objectives: To assess the efficacy of a novel nutraceutical mainly containing the extract of bitter gourd (*Momordica charantia*) and α -lipoic acid for the treatment of patients with hyperinsulinemia.

Methods: Pilot prospective open-label cohort trial including 11 patients with hyperinsulinemia due to insulin resistance. The concentrations of insulin, C-peptide, glucose, haemoglobin A1c, total cholesterol, triglycerids, gamma-glutamyltransferase, and C-reactive protein were measured in blood take between 3 and 4 hours after dinner.

Results: One and 4 months after initiation of treatment there was a significant decrease of the concentrations of Insulin (to average 25% of initial value), C-peptide (to average 44% of initial value), glucose, hemoglobin A1c and gamma-glutamyl transpeptidase.

Clinical significance: Treatment of patients with hyperinsulinemia, with or without diabetes or metabolic syndrome, using a novel nutraceutical containing *Momordica charantia* and α -lipoic acid dramatically reduced insulin resistance and may have improved non-alcoholic fatty liver disease.

Keywords: Insulin resistance; Hyperinsulinemia; *Momordica charantia*; Bitter gourd; Alpha lipoic acid; Nutraceutical

Introduction

Insulin resistance is the common denominator of the metabolic syndrome and obesity, pre-diabetes, and type 2 diabetes. It induces compensatory insulin hypersecretion. Impaired insulin sensitivity is frequent during statin treatment [1]. Hyperinsulinemia has been associated with prostate- [2] and breast cancer [3,4], and with non-alcoholic fatty liver disease.

In addition to live style adjustment and appropriate diet, Metformin is considered the first-line treatment of hyperinsulinemia. As efficient as this treatment may be, it is not devoid of serious side effects such as lactic acidosis, renal toxicity, and gastro-intestinal discomfort.

There are several non-pharmaceutical agents that counteract insulin resistance and may decrease hyperinsulinemia, of which the extract of *Momordica charantia* (bitter gourd or bitter melon) is well-known. Its mechanisms of action include increased phosphorylation of acetyl-CoA carboxylase and AMP-activated protein kinase (AMPK) [5], reduction of lipogenesis, enhanced thermogenesis and lipolysis [6]. The extract down-regulates the expression of peroxisome proliferator-activated receptor (PPAR)-gamma, nuclear factor kappaB (NF- κ B), and interferon-gamma in heart tissue, with cardio-protective effect thanks to reduction of inflammation [7]. In addition, *Momordica* exerts an interesting endocrine effect where it inhibits the enzyme 11 β -hydroxysteroid dehydrogenase type 1, that metabolises the mineralocorticoid cortisone to the glucocorticoid cortisol [8]. There is evidence for increased activity of this enzyme in adipose cells [9], and that this may be an important aetiological factor in the pathogenesis of obesity-associated insulin resistance.

Alpha-lipoic acid is a water soluble anti-oxidant which has been proven to reduce insulin resistance [10] in patients with type 2 diabetes [11] or obese and overweight non-diabetic men [12] and women [13], and it may potentially be used in cardiovascular diseases [14]. Alpha-lipoic acid was shown to improve angiogenesis and bioenergetics in hyperglycemia [15], and to upregulate irisin secretion in adipocytes, protecting against deleterious effects of glucose impairment [16].

The combination of *Momordica* extract and alpha-lipoic acid was expected to act in synergism because these agents are effective along different molecular pathways.

Here we report the results of an open-label, pilot trial of the treatment of a cohort of patients suffering from hyperinsulinemia, using a novel nutraceutical that combines the extract of *Momordica charantia* with alpha-lipoic acid.

Materials and Methods

Eleven consecutive patients consulting at the private clinic of the author and presenting hyperinsulinemia were invited to participate in an open-label, prospective trial using a novel nutraceutical containing 350 mg of the 1:4 extract of *Momordica charantia* and 50 mg alpha-lipoic acid (Cambridge Commodities, UK) in vegicaps (Pharmacy Van Wambeke, Elversele, Belgium)(Belgian patent # 1021188). Patients were requested to take 1 capsule after breakfast and one after dinner. The cohort consisted of 7 women and 4 men aged between 56 to 76 years. One woman was under treatment for type 2 diabetes with Metformin and Glipizide, with insufficient result and elevated haemoglobin A1c concentration. The nutraceutical was added to her initial medication. Patients were already given "healthy diet" recommendations before the initiation of the trial, emphasizing the

importance of reducing sugar and fructose intake. Two patients dropped out for personal reasons, though one patient resumed participation at a later date (data not included).

Before treatment was initiated, blood was taken, and this was repeated after 1 and 4 months of treatment. Blood was taken between 3 and 4 hours after lunch, and analysed for glycemia, haemoglobin A1c, insulin, C-peptide, triglycerids, total cholesterol, gamma glutamyl transpeptidase, and C-reactive protein (CRP) using well-established standard procedures (Anacura laboratory Ltd., Evergem, Belgium).

Results were plotted into the spreadsheet of the MedCalc statistical software (MedCalc Ltd, Ostend, Belgium) and described by means of parametrical (mean, standard deviation) and non-parametrical variables (median, 95% confidence intervals). Individual data of relevant biological markers are also presented in box-and-whisker plots with dots.

The significance of changes over time was assessed using the non-parametrical Wilcoxon’s signed-rank test for paired observations, that

is independent of the distribution of the data. The effective P-values of this test are listed.

Results

There was a highly significant correlation between the concentrations of insulin and C-peptide both before treatment ($r=0.92$, $P= 0.009$) and after 1 month of nutraceutical intake ($r=0.80$, $P=0.029$). The results of all measurements are listed in Table 1.

The concentrations of insulin, C-peptide, glycemia, gamma glutamyl transpeptidase and hemoglobin A1c presented a significant decrease ($P<0.05$) over the observation period (Table 2). Triglycerids, total cholesterol, and C-reactive protein did not change significantly. The individual values of insulin (Figure 1), C-peptide (Figure 2), and gamma glutamyl transpeptidase (Figure 3) are shown in box-and-whisker plots with dots.

Variable	Time 0 (mean, SD)	Time 0 (median, 95% CI)	1 mth (mean, SD)	1 mth (median, 95% CI)	1 mth (median, 95% CI)	4 mth (median, 95% CI)
insulin	75,6 (50,2)	76,8 (39,3-107,4)	41,1 (23,1)	39,9 (18,9-54,9)	18,7 (7,2)	17,7 (10,8-17,8)
C-peptide	9,38 (2,85)	8,41 (7,00-11,91)	6,27 (1,72)	5,96 (4,85-7,59)	4,18 (1,27)	3,83 (3,45-4,88)
glycemia	129 (39,1)	127 (99,3-167,1)	105,5 (18,8)	97 (89,0-126,1)	99,0 (27,6)	91,0 (80,2-119,5)
hemoglobin A1c	6,77 (1,7)	6,30 (5,56-8,21)	6,42 (1,57)	6,00 (5,34-7,26)	6,08 (0,86)	5,9 (5,42-6,70)
triglycerids	245 (96,6)	241 (176-314)	238 (137)	248 (68-408)	270 (114)	218 (130-412)
total cholesterol	209 (47,0)	202 (157-242)	208 (40,9)	202 (166-245)	229,7 (65,7)	210 (179-333)
gamma GT	42,3 (18,5)	41,5 (23,3-55,6)	36,4 (13,4)	37,0 (24,0-48,8)	31,8 (11,1)	34,0 (19,4-42,2)
C-reactive protein	3,67 (2,43)	3,70 (1,24-5,89)	2,67 (1,98)	2,1 (0,19-5,13)	4,72 (2,96)	4,65 (0,01-9,44)

Table 1: Time 0 lists the measurements before initiation of treatment. 1 month and 4 month list the measurements after respectively 1 and 4 months of intake of the nutraceutical. Gamma GT stands for gamma glutamyl transpeptidase. Values given are mean and standard deviation (SD), median and 95% confidence interval. Units: Insulin: $\mu\text{U/L}$; C-peptide: ng/mL ; Glycemia: mg/mL ; Hemoglobin A1c: %; Triglycerides: mg/dL ; total cholesterol: mg/dL , Gamma glutamyl transpeptidase: U/L ; C-reactive protein: mg/L .

Variable	Time 0 vs. 1 month	1 month vs. 4 month	Time 0 vs. 4 month
insulin	0.004	0.008	0.008
C-peptide	0.0003	0.008	0.0003
glycemia	0.037	0.54	0.039
hemoglobin A1c	0.031	0.63	0.031
triglycerids	0.44	0.91	0.54
total cholesterol	0.64	0.31	0.44
gamma GT	0.016	0.62	0.031
C-reactive protein	0.63	0.41	0.87

Table 2: P-values of the comparison between values measured at different time intervals, using the non-parametrical Wilcoxon signed-rank test for paired observations.

The concentrations of insulin (Figure 1), C-peptide (Figure 2), glycemia, gamma glutamyl transpeptidase (Figure 3) and hemoglobin A1c presented a significant decrease ($P < 0.05$) over the observation (Table 2). Triglycerids, total cholesterol, and C-reactive protein did not present significant changes.

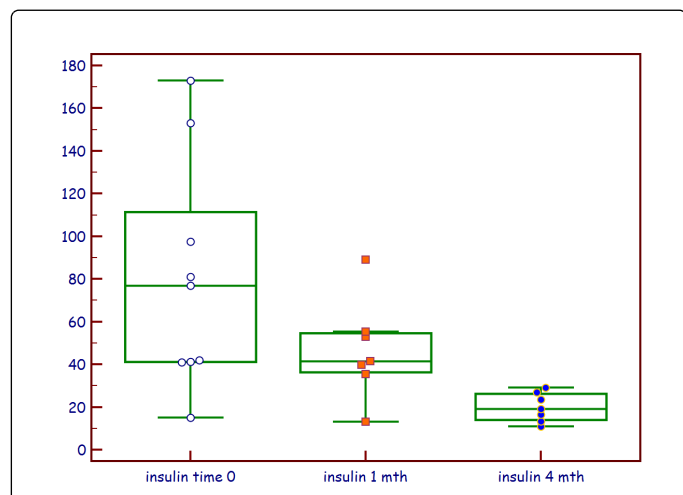

Figure 1: Box and whisker plots of Insulin concentration (in $\mu\text{U/L}$, on the vertical axis) at time 0, before initiation of treatment, after 1 month, and after 4 months of nutraceutical intake. The median is given, the boxes indicate the 25th and 75th percentile, and the whiskers correspond to the 5th and 95th percentile. Individual data are plotted.

Discussion

The benefit of *Momordica charantia* has been amply documented for the treatment of type 2 diabetes. It increases sensitivity of the insulin receptor [17], reduces insulin resistance and hyperinsulinemia, with favourably influence on the metabolic syndrome [18] and diabetes [19] in humans.

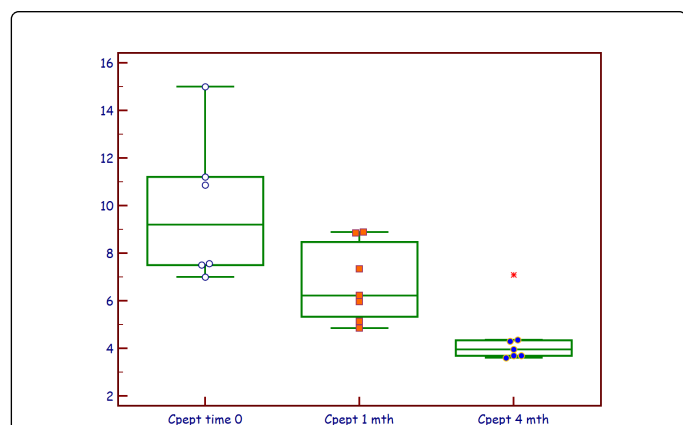

Figure 2: Box and whisker plot of C-peptide (in ng/mL). The median is given, the boxes indicate the 25th and 75th percentile, and the whiskers correspond to the 5th and 95th percentile. Individual data are plotted.

Obesity promotes prostate cancer [20] which has been related to hyperinsulinemia and insulin resistance [2, 21-23]. *Momordica* extract exerts chemo-protective effect against prostate cancer cells *in vitro* [24,25]. Its insulin-reducing effect may decrease neoplastic growth of the prostate in humans [26]. Also, insulin resistance has been found to impair cognitive function [27] and to promote Alzheimer disease [28]. The association between lower urinary tract symptoms (LUTS) and risk of dementia [29] may relate to hyperinsulinemia as common pathogenic factor. Therefore, decreasing insulin resistance may possibly contribute to the prevention of brain damage.

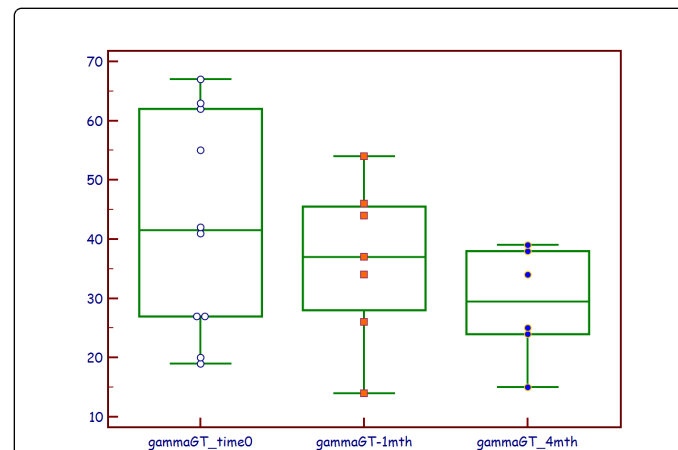

Figure 3: Box and whisker plot of gamma glutamyltranspeptidase (in U/L). The median is given, the boxes indicate the 25th and 75th percentile, and the whiskers correspond to the 5th and 95th percentile. Individual data are plotted.

Little is known about the efficiency of *Momordica*, associated with alpha-lipoic acid on hyperinsulinemia in patients, some of whom satisfy the criteria for the diagnosis of metabolic syndrome or with diabetes type 2. Clamp tests were not performed, but the recommendations of Jones and Hattersley [30] were implemented by measuring insulin and C-peptide in blood taken between 3 and 4 hours after dinner.

Under these circumstances all cases presented an important improvement of their metabolic status, with persistent reduction of the hyperinsulinemia and other biological markers. Serum gamma-glutamyl transpeptidase concentration was reported to distinguish non-alcoholic fatty liver disease at high risk [31,32] particularly in patients with the metabolic syndrome [33]. The decreased gamma-glutamyl transpeptidase activity observed during nutraceutical intake suggests a beneficial effect on non-alcoholic fatty liver disease [34,35], since this was shown to be associated with histologic improvement [36], and it may reduce the risk of developing type-2 diabetes [37].

There were no side effects, and gastro-intestinal tolerance was excellent. Vital signs and blood tests for renal function, and peripheral red and white blood cells count remained unchanged. Two cases mentioned weight loss over 10%, which they were unable to attain before initiation of treatment, even though adhering to the same diet.

Our findings underscore the benefit of nutraceutical treatment using the novel formulation in patients suffering from hyperinsulinemia, which should stimulate further research into its

possible effectiveness for the prevention of diseases associated with this condition.

Conclusion

The treatment of patients suffering from hyperinsulinemia with a nutraceutical mainly composed of the extract of *Momordica charantia* and the antioxidant alpha lipoic acid may be considered as an alternative for the conventional pharmaceutical approach. In this preliminary trial, including a limited number of cases, the nutraceutical was found to be effective as for as biological markers were concerned. It was well tolerated and devoid of side effects.

References

- Cederberg H, Stancakova A, Yaluri N, Modi S, Kuusisto J, et al. (2015) Increased risk of diabetes with statin treatment is associated with impaired insulin sensitivity and insulin secretion: a 6 year follow-up study of the METSIM cohort. *Diabetologia* 58: 1109-1117.
- Grossmann M, Wittert G (2012) Androgens, diabetes and prostate cancer. *Endocr Relat Cancer* 19: F47-F62.
- Gunter MJ, Xie X, Xue X, Kabat GC, Rohan TE, et al. (2015) Breast cancer risk in metabolically healthy but overweight postmenopausal women. *Cancer Res* 75: 270-274.
- Wysocki PJ, Wierusz-Wysocka B (2010) Obesity, hyperinsulinemia and breast cancer: novel targets and a role for metformin. *Expert Rev Mol Diagn* 10: 509-519.
- Tan, MJ, Ye JM, Turner N, Hohnen-Behrens C, Ke CQ, et al. (2008) Antidiabetic activities of triterpenoids isolated from bitter melon associated with activation of the AMPK pathway. *Chem. Biol* 15: 263-273.
- Chen PH, Chen GC, Yang MF, Hsieh CH, Chuang SH, et al. (2012) Bitter melon seed oil-attenuated body fat accumulation in diet-induced obese mice is associated with cAMP-dependent protein kinase activation and cell death in white adipose tissue. *J. Nutr.* 142: 1197-1204.
- Gadang V, Gilbert W, Hettiarachchy N, Horax R, Katwa L, et al. (2011) Dietary bitter melon seed increases peroxisome proliferator-activated receptor-gamma gene expression in adipose tissue, down-regulates the nuclear factor-kappaB expression, and alleviates the symptoms associated with metabolic syndrome. *J. Med. Food* 14: 86-93.
- Blum A, Loerz C, Martin HJ, Staab-Weijnitz CA, Maser E (2012) *Momordica charantia* extract, a herbal remedy for type 2 diabetes, contains a specific 11beta-hydroxysteroid dehydrogenase type 1 inhibitor. *J. Steroid Biochem. Mol. Biol.* 128: 51-55.
- Morton NM, Seckl JR (2008) 11beta-hydroxysteroid dehydrogenase type 1 and obesity. *Front Horm. Res.* 36: 146-164.
- Jacob S, Ruus P, Hermann R, Tritschler HJ, Maerker E, et al. (1999) Oral administration of RAC-alpha-lipoic acid modulates insulin sensitivity in patients with type-2 diabetes mellitus: a placebo controlled pilot trial. *Free Radic Biol Med* 27: 309-314.
- Hendriksen EJ, Diamond-Stanic MK, Marchionne EM (2011) Oxidative stress and the etiology of insulin resistance and type 2 diabetes *Free Radic Biol Med* 51: 993-999.
- Xiao C, Giacca A, Lewis GF (2011) Short-term oral alpha-lipoic acid does not prevent lipid-induced dysregulation of glucose homeostasis in obese and overweight nondiabetic men. *Am J Physiol Endocrinol Metabol* 301: E736-741.
- Capelli V, Di Sabatino A, Musacchio MC, De Leo V (2013) Evaluation of a new association between insulin-sensitizers and alpha-lipoic acid in obese women affected by PCOS. *Minerva Ginecol* 65: 425-433.
- Ghibu S, Richard C, Delemasure S, Vergely C, Zeller M, (2008) An endogenous dithiol with antioxidant properties: alpha-lipoic acid, potential uses in cardiovascular diseases. *Ann Cardiol Angeiol (Paris)* 57: 161-165.
- Coletta C, Modis K, Szczesny B, Brunyanski A, Olah G, et al. (2015) Regulation of vascular tone, angiogenesis and cellular bioenergetics by the 3-mercaptopyruvate sulfuryltransferase/H2S pathway: functional impairment by hyperglycemia and restoration by DL-alpha-lipoic acid. *Mol Med* 21: 1-14.
- Huerta AE, Prieto-Hontoria PL, Fernandez-Galilea M, Sainz N, Cuervo N, et al. (2015) Circulating irisin and glucose metabolism in overweight/obese women: effects of alpha-lipoic acid and eicosapentaenoic acid. *J Physiol Biochem* 28.
- Shetty AK, Kumar GS, Sambaiah K, Salimath PV (2005) Effect of bitter gourd (*Momordica charantia*) on glycaemic status in streptozotocin induced diabetic rats. *Plant Foods Hum. Nutr.* 60: 109-112.
- Tsai CH, Chen EC, Tsay HS, Huang CJ (2012) Wild bitter gourd improves metabolic syndrome: a preliminary dietary supplementation trial. *Nutr. J.* 11: 4.
- Rizvi SI, Mishra N (2013) Traditional Indian medicines used for the management of diabetes mellitus. *J. Diabetes Res.* 712092.
- Lee A, Chia SJ (2015) Prostate cancer detection; The impact of obesity on Asian men. *Urol Oncol* 9 pii: S1708-1439.
- Allott EH, Masko EM, Freedland SJ (2013) Obesity and prostate cancer: weighing the evidence. *Eur. Urol.* 63: 800-809.
- Arcidiacono B, Iiritano S, Nocera A, Possidente K, Nevoletto MT, et al. (2012) Insulin resistance and cancer risk: an overview of the pathogenetic mechanisms. *Exp. Diabetes Res.* 789174.
- Vardhan SP, Krishnamma A, Naidu JN, Naidu MP (2014) Study of insulin resistance and antioxidant vitamin status in prostate cancer patients. *Int. J. Res. Med. Sci.* 2: 643-646.
- Ru P, Steele R, Nerurkar PV, Phillips N, Ray RB (2011) Bitter melon extract impairs prostate cancer cell-cycle progression and delays prostatic intraepithelial neoplasia in TRAMP model. *Cancer Prev. Res. (Phila)* 4: 2122-2130.
- Pitchakarn P, Suzuki S, Ogawa K, Pompimon W, Takahashi S, et al. (2012) Kuguacin J, a triterpenoid from *Momordica charantia* leaf, modulates the progression of androgen-independent human prostate cancer cell line, PC3. *Food Chem. Toxicol.* 50: 840-847.
- Nandeesh H (2009) Insulin: a novel agent in the pathogenesis of prostate cancer. *Int. Urol. Nephrol.* 41: 267-272.
- Sasaoka T, Wada T, Tsuneki H (2014) Insulin resistance and cognitive function. *Nihon Rinsho* 72: 633-640.
- De Felice FG (2013) Alzheimer's disease and insulin resistance: translating basic science into clinical applications. *J. Clin. Invest.* 123: 531-539.
- Janecko LL (2015) Older adults with lower urinary tract symptoms have increased dementia risk. *DGNews. 30th International Conference of Alzheimer Disease International (ADI) Perth, April 21.*
- Jones AG, Hattersley AT (2013) The clinical utility of C-peptide measurement in the care of patients with diabetes. *Diabet Med* 30: 803-807.
- Tahan V, Cabakan B, Balci H, Dane F, Akin H, et al. (2008) Serum gamma-glutamyltranspeptidase distinguishes non-alcoholic fatty liver disease at high risk. *Hepatogastroenterology* 55: 1433-1438.
- Frazini M, Fornaciari I, Fierabracci V, Elawadi HA, Bolognesi V, (2012). Accuracy of b-GGT fraction for the diagnosis of non-alcoholic fatty liver disease. *Liver Int* 32: 629-634.
- Banderas DZ, Escobedo J, Gonzalez E, Liceaga MG, Ramirez JC, (2012) gamma-glutamyl transferase: a marker of non-alcoholic fatty liver disease in patients with the metabolic syndrome. *Eur J Gastroenterol Hepatol* 24: 805-810.
- Salgado W, dos Santos JS, Sankarankutty AK, De Castro e Silva O (2006) Nonalcoholic fatty liver disease and obesity. *Acta Cir Bras* 21 suppl. 1: 72-78.
- Fabbrini E, Sullivan S, Klein S (2010) Obesity and nonalcoholic fatty liver disease: biochemical, metabolic and clinical implications. *Hepatology* 51: 679-689.

-
36. Dixon JB, Bhatal PS, O'Brien PE (2006) Weight loss and non-alcoholic fatty liver disease: falls in gamma-glutamyl transferase concentration are associated with histologic improvement. *Obes Surg* 16: 1278-1286.
37. Lim SJ, Lee DH, Park JY, Jin SH, Jacobs DR Jr. (2007) A strong interaction between serum gamma-glutamyltransferase and obesity on the risk of prevalent type 2 diabetes: results from the Third National Health and Nutrition Examination Survey. *Clin Chem* 53: 1092-1098.